

NOTICE: This document contains references to Varian. Please note that Varian, Inc. is now part of Agilent Technologies. For more information, go to www.agilent.com/chem.



Diffusion Pumps for Applied Films Glass Coating Systems

*INSTRUCTION MANUAL
SUPPLEMENT*

VHS-10 AND HS-16

Manual Number 699901575
Revision C
April 2006

Diffusion Pumps for Applied Films Glass Coating Systems

Warranty

Products manufactured by Seller are warranted against defects in materials and workmanship for twelve (12) months from date of shipment thereof to Customer, and Seller's liability under valid warranty claims is limited, at the option of Seller, to repair, to replace, or refund of an equitable portion of the purchase price of the Product. Items expendable in normal use are not covered by this warranty. All warranty replacement or repair of parts shall be limited to equipment malfunctions which, in the sole opinion of Seller, are due or traceable to defects in original materials or workmanship. All obligations of Seller under this warranty shall cease in the event of abuse, accident, alteration, misuse, or neglect of the equipment. In-warranty repaired or replaced parts are warranted only for the remaining unexpired portion of the original warranty period applicable to the repaired or replaced parts. After expiration of the applicable warranty period, Customer shall be charged at the then current prices for parts, labor, and transportation.

Reasonable care must be used to avoid hazards. Seller expressly disclaims responsibility for loss or damage caused by use of its Products other than in accordance with proper operating procedures.

Except as stated herein, Seller makes no warranty, express or implied (either in fact or by operation of law), statutory or otherwise; and, except as stated herein, Seller shall have no liability under any warranty, express or implied (either in fact or by operation of law), statutory or otherwise. Statements made by any person, including representatives of Seller, which are inconsistent or in conflict with the terms of this warranty shall not be binding upon Seller unless reduced to writing and approved by an officer of Seller.

Disclaimer

Operation and maintenance of this equipment involves serious risk. It is the responsibility of the user to maintain safe operating conditions at all times. Varian Inc./Applied Films assume no liability for personal injury or damage resulting from operation or service of the equipment.

Varian Inc./Applied Films have no control over the use of this equipment and is not responsible for personal injury or damage resulting from its use. The safe use and disposal of hazardous or potentially hazardous materials of any kind is the sole responsibility of the user. Observe all WARNINGS and CAUTIONS to minimize the serious hazards involved.

It is the sole responsibility of the users of Varian, Inc./Applied Films equipment to comply with all local, state and federal safety requirements (laws and regulations) applicable to their system. Employ the services of an industrial hygienist and/or a qualified chemical safety engineer in order to ensure safe installation and use.

Warranty Replacement and Adjustment

All claims under warranty must be made promptly after occurrence of circumstances giving rise thereto, and must be received within the applicable warranty period by Seller or its authorized representative. Such claims should include the Product serial number, the date of shipment, and a full description of the circumstances giving rise to the claim. Before any Products are returned for repair and/or adjustment, written authorization from Seller or its authorized representative for the return and instructions as to how and where these Products should be returned must be obtained. Any Product returned to Seller for examination shall be prepaid via the means of transportation indicated as acceptable by Seller. Seller reserves the right to reject any warranty claim not promptly reported and any warranty claim on any item that has been altered or has been returned by non-acceptable means of transportation. When any Product is returned for examination and inspection, or for any other reason, Customer shall be responsible for all damage resulting from improper packing or handling, and for loss in transit, notwithstanding any defect or non-conformity in the Product. In all cases, Seller has the sole responsibility for determining the cause and nature of failure, and Seller's determination with regard thereto shall be final.

If it is found that Seller's Product has been returned without cause and is still serviceable, Customer will be notified and the Product returned at its expense; in addition, a charge for testing and examination may be made on Products so returned.

3/1/00

To Contact Varian, Inc.

In the United States, you can contact Varian, Inc. Customer Service at 1-800-8VARIAN.

Internet users:

- Send email to Customer Service & Technical Support at vpl.customer.support@varianinc.com
- Visit our web site at www.varianinc.com/vacuum
- Order on line at www.evarian.com

See the back cover of this manual for a listing of our sales and service offices.

To Contact Diffusion Pumps for Applied Films

1. Internet at www.appliedfilms.com
 - For customer support launch, *customer care* to input a detailed technical issue. Expect a response within one business day.
2. E-mail
 - Contact Jay Cowan, Customer Support manager, jay.cowan@appliedfilms.com
3. Telephone
 - Request customer support, toll free (US only) 1-800-523-7213
 - Request customer support, direct dial +1-707-423-2109
4. Fax
 - Request customer support via fax +1-707-425-6071

This page intentionally left blank.

General

Varian, Inc. supplies VHS-10 and HS-16 diffusion pumps customized for use in coating systems produced by Applied Films. This manual supplements the standard VHS-10 and HS-16 diffusion pump instruction manuals. Refer to the standard instruction manuals for general information regarding safety, installation, operation and maintenance. These manuals can be purchased through Varian, Inc. (Table 1).

Table 1 Diffusion Pump Instruction Manual Part Number

Diffusion Pump	Instruction Manual Part Number
VHS-10	699901023
HS-16	699901140

The pumps differ from the standard Varian, Inc. offerings in the following ways:

- ❑ A custom inlet baffle is installed on the pumps to optimize the pump speed for coating applications.
- ❑ The electrical box has been relocated to under the foreline (HS-16 only) and an electrical connector has been added to reduce installation time.
- ❑ The HS-16 cooling system has been modified to reduce installation time. There is now only one water inlet and one water outlet on the pump. The standard VHS-10 pump already provides this water hookup option. Both the VHS-10 and HS-16 are fitted with custom water connections using the customer specified thread sizes.

Refer to Figure 1 on page 3 and Figure 2 on page 4 for pump dimensions.

Field Replacement Parts

Refer to the VHS-10 or HS-16 instruction manual for a full listing of replacement parts available for these pumps. Table 2 lists the heater and crush plate part numbers by model number.



Crush plates are not reusable and are changed with every heater replacement.

Table 2 Replacement Heater and Crush Plate Part Numbers

Pump Part No.	Voltage/ Wattage	Pump Type	Heater Part No.	Crush plate Part No.
R1330310	380 V/3200 W	HS-16	647316051	K4919001
R1330311	440 V/3200 W	HS-16	647316042	K4919001
R1330312	480 V/3200 W	HS-16	647316033	K4919001
R2356301	380 V/2200 W	VHS-10	647310160	K7667001
R2356302	400 V/2200 W	VHS-10	647310190	K7667001
R2356303	440 V/2200 W	VHS-10	647310200	K7667001
R2356304	480 V/2200 W	VHS-10	647310170	K7667001

Electrical Wiring

Electrical power is supplied to the pumps through a power connector mounted on the electrical box. A spare connector and wire harness is available through Varian, Inc. (PN# R2323002 (VHS-10) or R2323001 (HS-16)). The mating (female) connector is available (PN# R2323003, same part number for either VHS-10 or HS-16). Refer to Figure 3 and Figure 4 on page 5 for pump wiring diagrams.

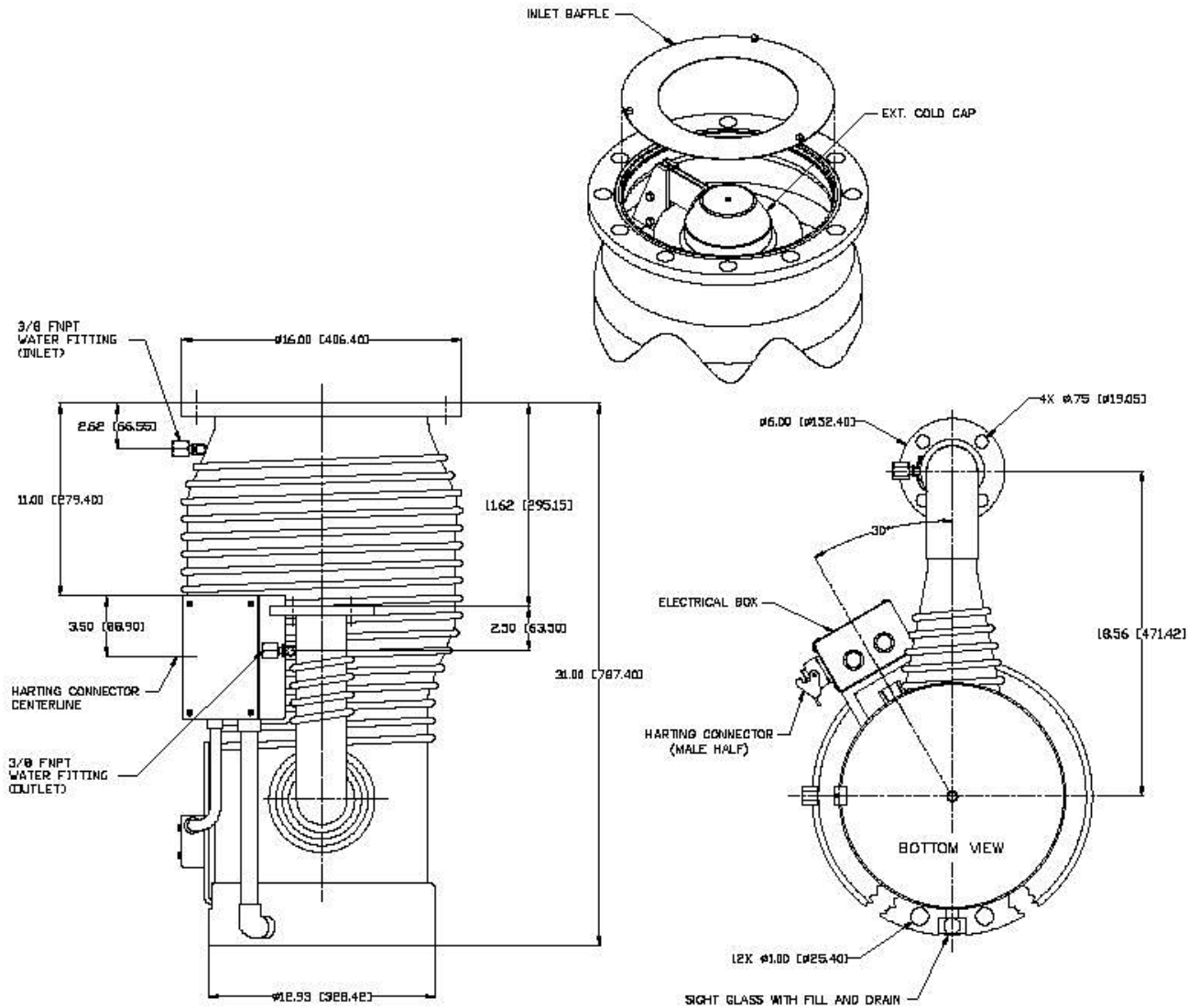

Figure 1 VHS-10 Dimension Diagram

Diffusion Pumps for Applied Films Glass Coating Systems

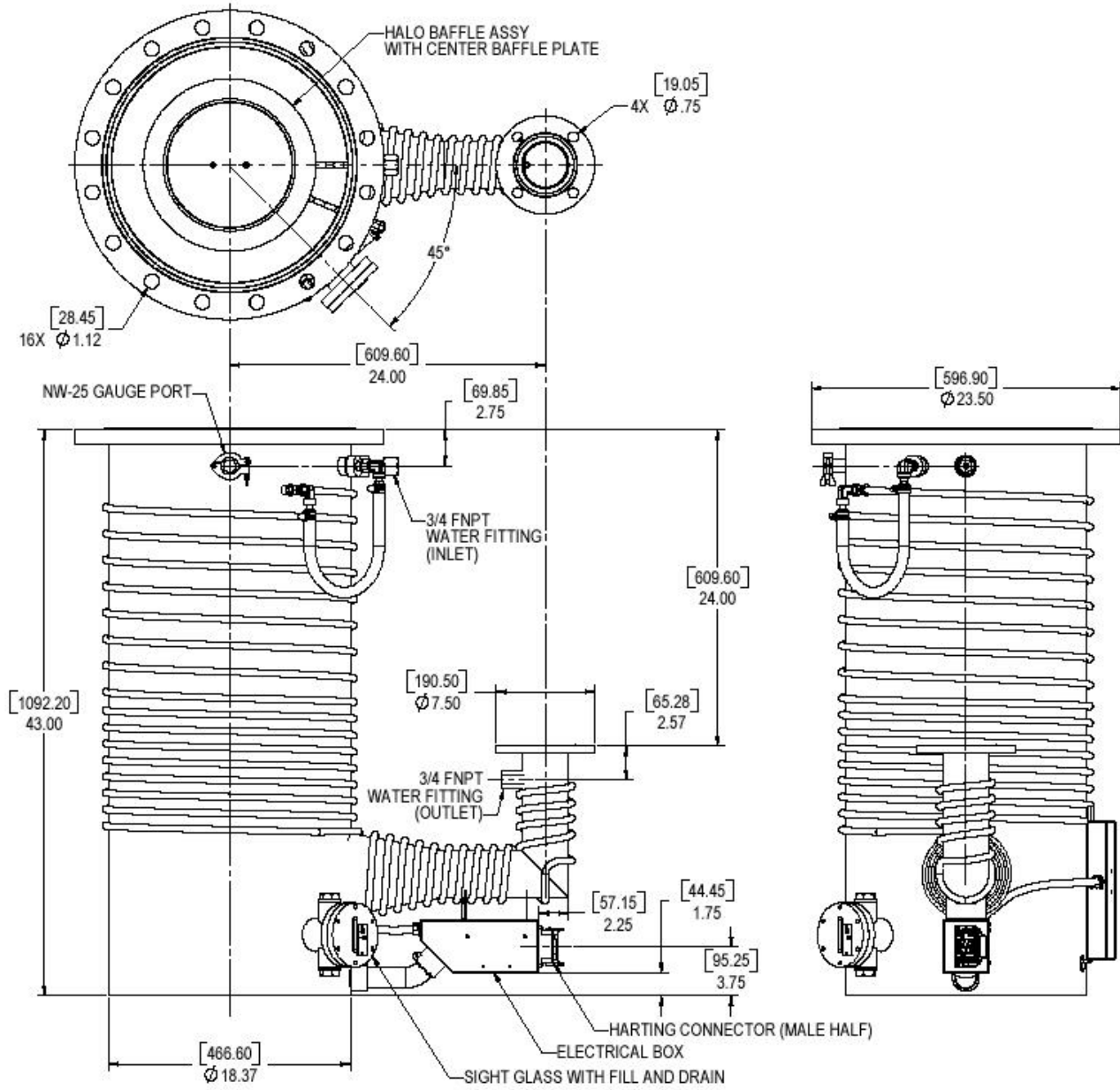

Figure 2 HS-16 Dimension Diagram

Diffusion Pumps for Applied Films Glass Coating Systems

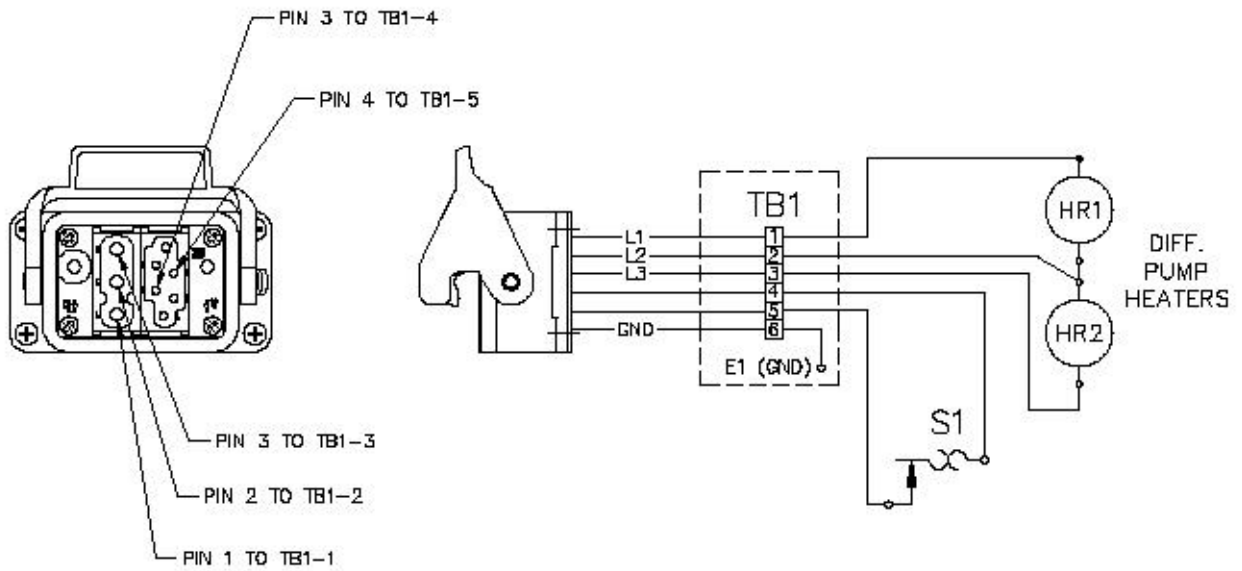

Figure 3 VHS-10 Wire Schematic

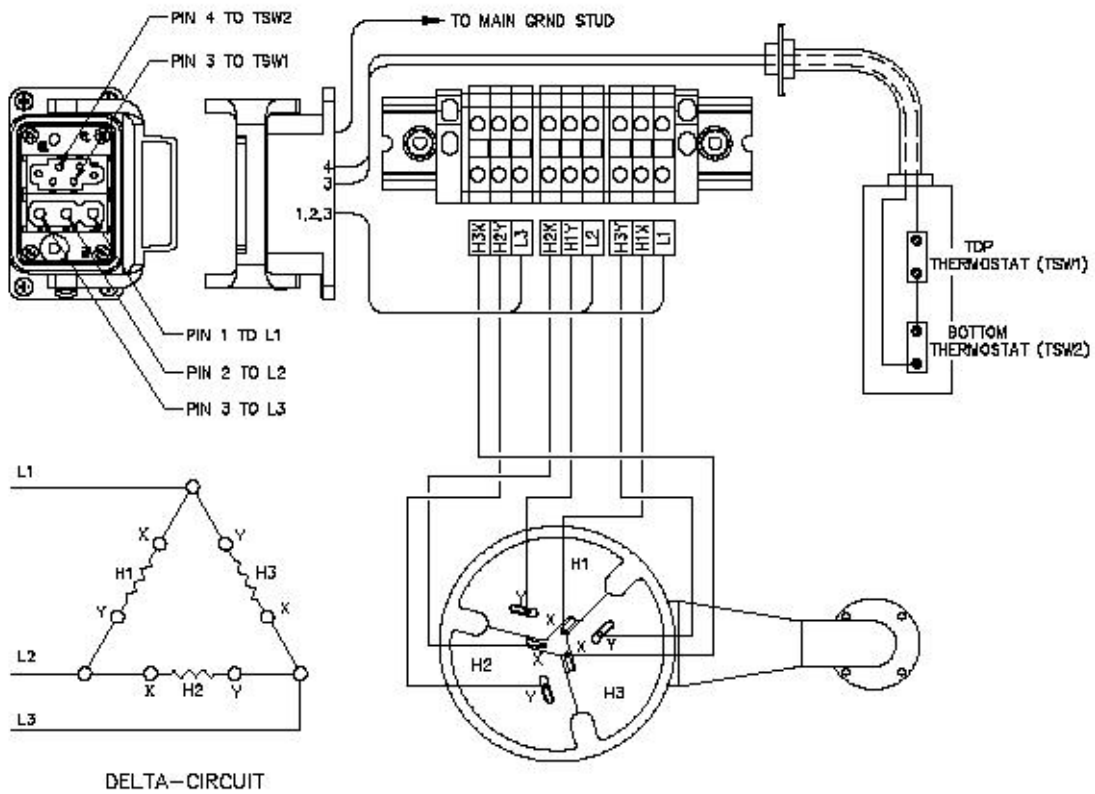

Figure 4 HS-16 Wire Schematic

This page intentionally left blank.

Sales and Service Offices

Canada

Central coordination through:

Varian, Inc.
121 Hartwell Avenue
Lexington, MA 02421
USA
Tel: (781) 861 7200
Fax: (781) 860 5437
Toll Free: (800) 882 7426

China

Varian Technologies - Beijing

Room 1201, Jinyu Mansion
No. 129A, Xuanwumen Xidajie
Xicheng District
Beijing 1000031
P.R. China
Tel: (86) 10 6608 1031
Fax: (86) 10 6608 1541

France and Benelux

Varian s.a.

7 avenue des Tropiques
Z.A. de Courtaboeuf – B.P. 12
Les Ulis cedex (Orsay) 91941
France
Tel: (33) 1 69 86 38 13
Fax: (33) 1 69 28 23 08

Germany and Austria

Varian Deutschland GmbH

Alsfelder Strasse 6
Postfach 11 14 35
64289 Darmstadt
Germany
Tel: (49) 6151 703 353
Fax: (49) 6151 703 302

India

Varian India PVT LTD

101-108, 1st Floor
1010 Competent House
7, Nangal Raya Business Centre
New Delhi 110 046
India
Tel: (91) 11 5548444
Fax: (91) 11 5548445

Italy

Varian, Inc.

Via F.Ili Varian, 54
10040 Leini, (Torino)
Italy
Tel (39) 011 997 9 111
Fax (39) 011 997 9 350

Japan

Varian, Inc.

Sumitomo Shibaura Building, 8th Floor
4-16-36 Shibaura
Minato-ku, Tokyo 108
Japan
Tel: (81) 3 5232 1253
Fax: (81) 3 5232 1263

Korea

Varian Technologies Korea, Ltd.

Shinsa 2nd Building 2F
966-5 Daechi-dong
Kangnam-gu, Seoul
Korea 135-280
Tel: (82) 2 3452 2452
Fax: (82) 2 3452 2451

Mexico

Varian S.A.

Concepcion Beistegui No 109
Col Del Valle
C.P. 03100
Mexico, D.F.
Tel: (52) 5 523 9465
Fax: (52) 5 523 9472

Russia

Central coordination through:

Varian, Inc.
via F.Ili Varian 54
10040 Leini, (Torino)
Italy
Tel: (39) 011 997 9 252
Fax: (39) 011 997 9 316

Taiwan

Varian Technologies Asia Ltd.

18F-13 No.79, Hsin Tai Wu Road
Sec. 1, Hsi Chih, Taipei Hsien
Taiwan, R.O.C.
Tel: (886) 2 2698 9555
Fax: (886) 2 2698 9678

UK and Ireland

Varian Ltd.

28 Manor Road
Walton-On-Thames
Surrey KT 12 2QF
England
Tel: (44) 1932 89 8000
Fax: (44) 1932 22 8769

United States

Varian, Inc.

121 Hartwell Avenue
Lexington, MA 02421
USA
Tel: (781) 861 7200
Fax: (781) 860 5437

Other Countries

Varian, Inc.

Via F.Ili Varian 54
10040 Leini, (Torino)
Italy
Tel: (39) 011 997 9 111
Fax: (39) 011 997 9 350

Customer Support and Service:

North America

Tel: 1 (800) 882-7426 (toll-free)
vtl.technical.support@varianinc.com

Europe

Tel: 00 (800) 234 234 00 (toll-free)
vtl.technical.support@varianinc.com

Japan

Tel: (81) 3 5232 1253 (dedicated line)
vtj.technical.support@varianinc.com

Korea

Tel (82) 2 3452 2452 (dedicated line)
vtk.technical.support@varianinc.com

Taiwan

Tel: 0 (800) 051 342 (toll-free)
vtw.technical.support@varianinc.com

Worldwide Web Site, Catalog and On-line Orders:

www.varianinc.com

Representatives in most countries



VARIAN